

Leddex

LED LIGHTING SOLUTIONS: DESIGN – SUPPLY – MANUFACTURE

Leddex Lightbox

LARGE SIZE LED PANELS

APPLICATIONS

Frameless Textile LED Backlit Light Box

Advertising design: bright signs and displays

Interior design as decorative wall

Public /business spaces decor

Trade fairs

FEATURES

- For interior advertising and showcase.
- Single-sided, mounting on the wall or suspended.
- Easy changeable high quality textile print.
- Customisable
- Unlimited size.
- Brightness up to 11000lx on the surface depending on size.
- Low power consumption.

LARGE SIZE LED PANELS

Lumaire Light Box



- Frame thickness 100 mm
- Unlimited size
- Mounting options
- Low power consumption
- For interior displays and showcases
- Changeable textile print

3 YEARS WARRANTY

SUPPORT 24/7, PROTECTION & WARRANTY



VARIATIONS

1. Pre-drill installation with thread nuts

Lumaire Light Box with textile front, wall-mounted. The textile backlit spreads light evenly over the entire surface.







2. Cable fixation / Cable holder

The ceiling mounting kit for one-sided Light Box.

3. Portable stand

Choose a portable stand to your Lumaire Light Box.

Technical specifications

<p>MAIN MATERIALS Aluminium frame and textile covering</p>	<p>LUMINOUS EFFICIENCY up to 160 lm/W</p>	<p>POWER SUPPLY DC 12V / 24V / CC Adaptor</p>	<p>COLOUR TEMPERATURE</p> <ul style="list-style-type: none">  3000 K  4000 K  5000 K  6500 K  CCT (Special order)  RGB (Special order; except Magnetic Slim profile)
<p>FRAME THICKNESS 100 mm</p>	<p>IP RATING IP 20</p>	<p>WORKING VOLTAGE DC 12V / DC 24V / DC CC <small>(RGB only 12 V)</small></p>	
<p>UNLIMITED SIZE Panels are connectable</p>	<p>LIFETIME > 50,000 hours</p>	<p>INPUT VOLTAGE AC 100 ~ 240V 50/60Hz</p>	
<p>PACKAGE INCLUDES: Power supply (Mean well GST series power supply)</p>	<p>OPERATING TEMPERATURE -30°C ~ + 40°C</p>	<p>LED TAPE POWER 15 W/m</p>	

Fixing & mounting

1. Cable fixation

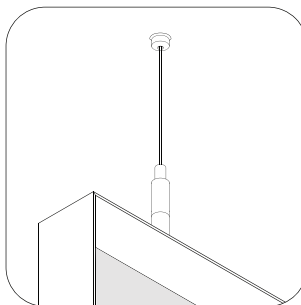
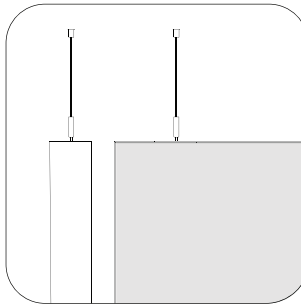
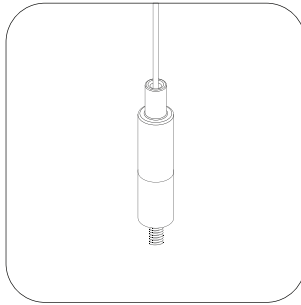

2. Pre Drill installation

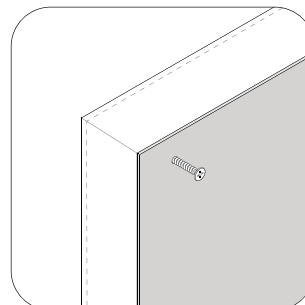
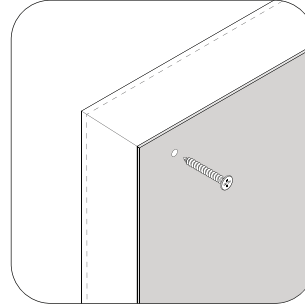
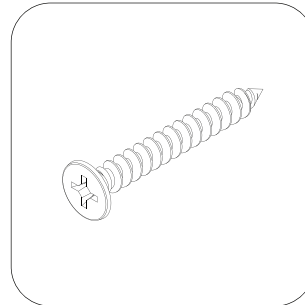

3. Portable stand

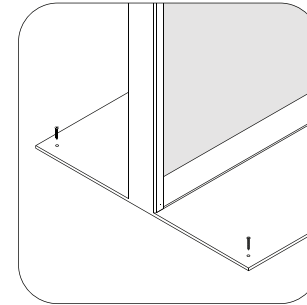
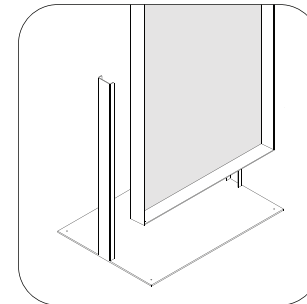
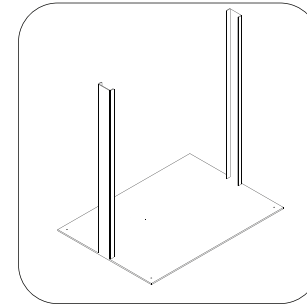

PRODUCT STRUCTURE

Technical & usage

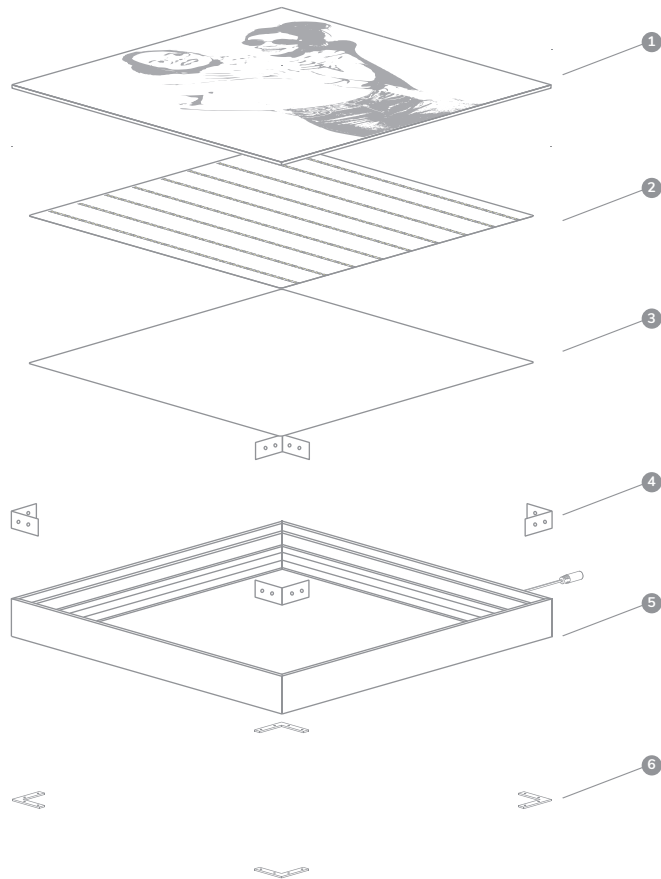

1. Textile Print
2. Lumaire LED strips
3. Reflector

4. Mounting Angles
5. Aluminium frame
6. Brackets

1. Textile Print

Final step of the light box to choose, design and manufacture the desirable print you want to light up. Every standard textile and rigid print works perfectly with Leddex light panels

2. LED strips

High power LED strips with integrated Intelligent Control (IC) system for ultimate reliability and maximum lighting effect.

3. Reflector

White light box background to reflect and evenly distribute the light, creating an even and bright illumination of the Textile Print.

5. Aluminium frame

A flexible material designed for supreme light reflection and color enhancement, making the most of LED lighting and acrylic sheet

Example

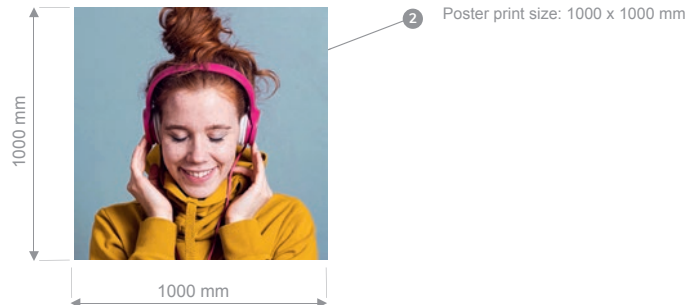
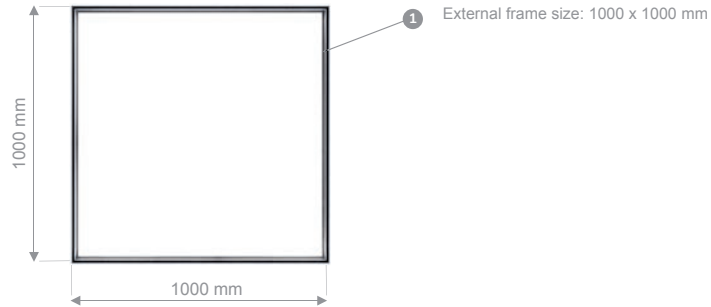

PRINT - BACKLIT

Lumaire Box Textile frame: file preparation

PRINTING SIZE

The print size should be the same as the external frame, with no bleeds.

DIGITAL PRINTING

For color profile and graphic file preparation for printing, please get in touch with your printing house.

We are here to provide you with reliable services.
Because we are the ones

— who inspire through light

CONTACT:

Phone

Phone: +370 5 212 7244
Mobile: +370 606 56703

Address

Elektrinės str. 8, LT-03150
Vilnius, Lithuania

Email

Mail 01: info@leddex.eu
Mail 02: export@leddex.eu